



KERNLOCHBOHRER[®]
PROFESSIONAL POWER TOOLS



Operating instructions

Core drill rig

KBS-252/M-PRO

Kernlochbohrer GmbH
Geigersbühlweg 52
72663 Großbettlingen
Phone: 07022-5034900
E-Mail: info@kernlochbohrer.com

Version 0 2. Output 05/2023

Content

Introduction and description	3
Thanks to the buyer	3
Explanation of symbols	3
Safety regulations	4
Product description	6
Technical data	7
Mounting the drill stand	7
Care and maintenance	11
Maintenance and inspection plan	13
Troubleshooting	14
Exploded view	15
Environmental protection	17
Warranty	17
EC Declaration of Conformity	Attachment

Introduction and description

The KBS-252/M-PRO core drilling rig is designed for mounting diamond core drilling equipment. This is intended for professional use and may only be used by trained personnel.

In the event of violations of the operating instructions, which may lead to injuries or machine damage, our company declines all responsibility. In addition, all currently applicable regulations of the Accident Prevention Regulations (UVV) and the Employer's Liability Insurance Association (BG) must be observed.

Thanks to the buyer

Thank you for purchasing a core drill rig from Kernlochbohrer GmbH. Please read the operating instructions carefully and observe the safety instructions. Through proper operation, you will fully appreciate the outstanding performance of our products. Keep this manual in a safe place for future reference. If you have any questions regarding the operation of the core drill, please contact Core Drill GmbH directly. We are available to answer your questions at any time.

Note:

Kernlochbohrer GmbH reserves the right to change the design and appearance of the products and their operating instructions. Future changes to the operating instructions will be made without prior notice.

Explanation of symbols



General Danger Warning. Failure to follow these safety precautions and instructions may result in electric shock, fire and/or serious injury.

Safety regulations

- ❖ Read all precautions before start-up and keep the operating instructions.
- ❖ Please follow the operating instructions carefully, as failure to follow these safety precautions and instructions may cause electric shock, fire and/or serious injury.

1. Keep your work area clean and well lit. Disorder or unlit work areas can lead to accidents.
2. Do not work with power tools, near flammable liquids, gases or dust. Power tools produce sparks that can ignite dust or fumes, causing explosions.
3. Keep children and other persons away from tools during use. If you become distracted, you may lose control of the tool.
4. Be attentive, work with concentration and pay attention to what you are doing. Do not use a power tool when you are tired or under the influence of drugs, alcohol or medication. A moment of inattention can result in serious injury.
5. Wear suitable protective equipment and always protective goggles. Wearing suitable protective equipment such as dust mask, non-slip safety shoes, gloves, hard hat or hearing protection reduces the risk of injury.



6. Avoid unusual postures. Ensure a secure footing and maintain your balance at all times. Do not work on a ladder. This will give you better control of the power tool in unexpected situations.
7. Wear appropriate clothing. Do not wear loose clothing or jewelry. Keep hair, clothing and gloves away from moving parts. Loose clothing, jewelry or long hair can be caught by moving parts.
8. The use of products such as cutters, grinders, drills that machine sand or other materials can generate dust and fumes that may contain hazardous chemicals. Check the type of material you are going to machine and use a suitable respirator.
9. Never work alone, always make sure that another person is nearby. Apart from the fact that you can get help with the assembly of the drill, you can also get help if an accident should happen.
10. Never use a drilling instrument that is faulty. Carry out the maintenance and service instructions described in this manual. Some maintenance and service measures must be performed by trained and qualified personnel.
11. Before mounting the drill motor and drill bit, make sure that the stand is properly secured.
12. Der Bohrstander muss auf einer ebenen und festen Oberfläche befestigt werden. Bohrungen mit einem lockeren und/oder taumelnden Ständer können zu einer gefährlichen Situation führen.
13. The core drill rig serves the intended purpose of mounting the drill motor for stationary drilling. All other uses not intended for the intended purpose are prohibited.

14. Always use compatible drilling tools with the drill stand. The connection on the power tools must be in accordance with the stand.
15. When used for overhead drilling, a functional water collection ring must be used. Make sure that no water can get into the motor.
16. Check all moving and clamped parts before use.
17. Only use original spare parts from Kernlochbohrer GmbH.

Product description



- | | | | |
|----|----------------|-----|--------------------|
| 1. | Drill column | 7. | Slide lever lock |
| 2. | Hand crank | 8. | Dragonfly |
| 3. | Angle clamp | 9. | Clamp mount Ø 60mm |
| 4. | Column support | 10. | Drill slide |
| 5. | Column holder | 11. | Leveling screw |
| 6. | Base plate | | |

Technical data

Model:	KBS-252/M-PRO
Item number:	6217
Max. Drill size:	252mm
Drill column:	60x62x900mm
Drilling stroke:	580mm
Motor mount:	Ø 60mm Bracket
N.W.	11,5kg
Packing size:	1045x290x455mm

Mounting the drill stand

Determine the desired position of the stand. Then fasten the stand with a concrete anchor. To do this, drill a hole of suitable size for the anchor using a hammer drill.



When anchoring to a brick wall, a special masonry anchor and brick fixing kit must be used. Using a concrete drive-in anchor in brick could result in brick breakage and loosening of the anchor!

If you use our vacuum base plate VGP-420/PRO to fix the core drill rig, make sure that the vacuum is at least -0.8bar and make sure that the seal is not worn or damaged.



Warning!

In the case of overhead drilling, vacuum attachment to the ceiling is prohibited as it can cause serious injury.

To bring the drill stand into the correct position, use the four leveling screws and the level indicator attached to the drill carriage for this purpose. Then tighten the lock nuts on the leveling screws. The entire stand must be firmly mounted.



Adjust the angle of the drill stand to the position using the drill center of the desired drill hole. The adjustable drilling angle ranges from 0° to 45°. If you need to drill at 45°, loosen the clamping screw with the attachable 13mm crank handle.



Loosen the clamping screw on the column support and set the angle according to the scale on the drill column. Once the angle is set, tighten the clamping screw again. Make sure that the mounting adapter and the carriage are fixed.

Note!

Do not overtighten the clamping screw, otherwise the column support and the bracket may deform.

Check if the guide on the column is loose. If it is loose, you must adjust the 4 eccentric clamps inside the drill carriage. Use a 13mm wrench and an 8mm wrench to tighten the clamping nut. Now test the correct fit of the drill slide by cranking it up and down. There should be no free play, but also no jamming throughout the travel.

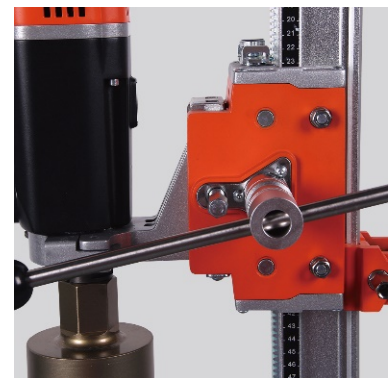

The KBS-252/M-PRO has both a clamp bracket and a mounting adapter. Both mounting methods depend on the type of drill motor. e.g. the DKB-202/H-PRO is a handheld drill motor, this must be used with the clamp bracket when mounted on the stand.

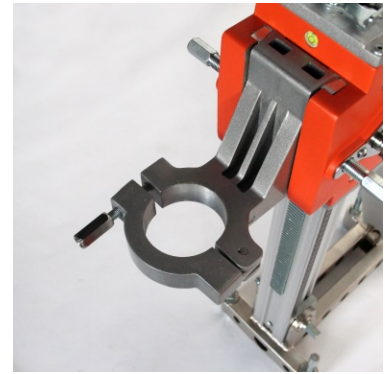

Before mounting the drill motor on the stand, first set the drill slide to a higher position to make it easier to insert the adapter plate

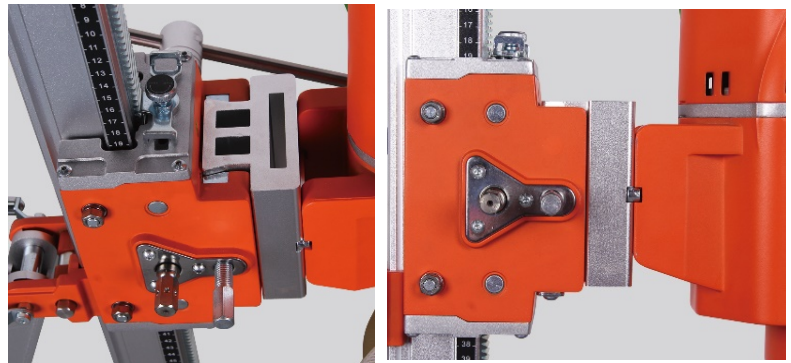

When mounting a DKB-PRO series drill rig with mounting adapter on the KBS-252/M-PRO core drill rig, you first need 4 screws to attach the mounting adapter to the motor. There is a 10x10x100mm keyway on the mounting adapter, which absorbs the torque of the motor via the key. Now adjust the locking screw so that the fastening adapter can be inserted effortlessly. Now place the fastening adapter with the dovetail in the guide. Tighten the locking screw until the plate is secured in the guide. To be able to remove the drill motor again, loosen the fastening screw completely.

The locking device of the drill carriage is located on the top side of the drill carriage. It is intended to prevent the drill sled from falling down and causing possible injury or damage to the drill or the machine.

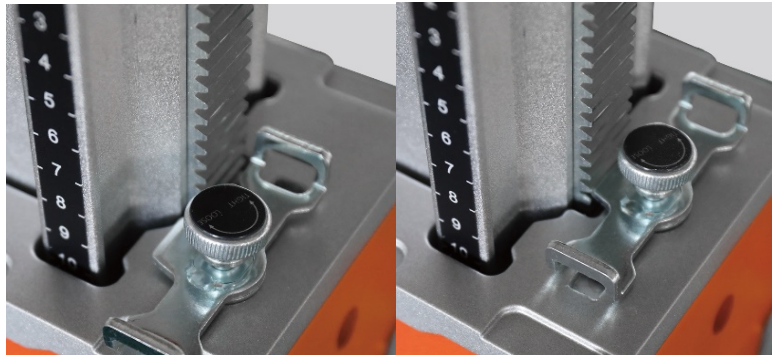

Slide the carriage lock to the left to unlock the carriage, then crank the drill carriage up or down to the desired position and slide the lever lock to the right to lock the drill carriage. After making the desired adjustments, such as inserting the motor, unlock the locking device and tighten the thumbscrew on the lever lock to begin operation.

Note!

Do not crank the carriage up and down when the lever lock is in the locked position, as this will damage both the rack and the lever lock.

For easy removal of the drill, use the quick-change ring which is placed on the drill shaft in front of the drill bit.

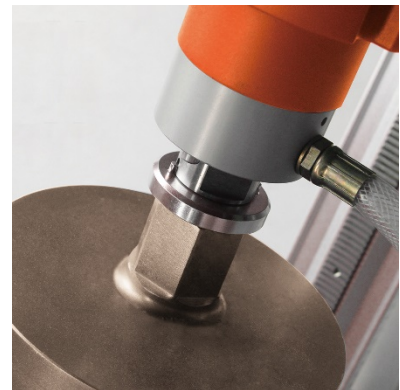

The cup wing nut of the cord threaded rod (in the optional fastening set) is a large wing-shaped nut with washer. It can be used together with an impact anchor to fasten the drill stand to the substrate.

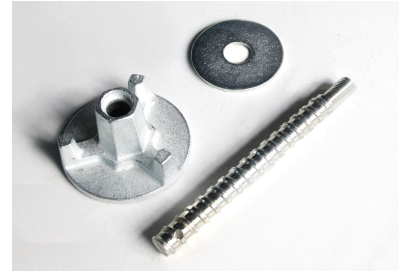

If you are drilling a wall hole with a stand, first securely fasten the stand to the wall, and only then mount the drill motor on the stand.

Care and maintenance

Repairs may only be carried out by qualified personnel suitable on the basis of their training and experience. The core drill rig is designed to require a minimum of care and maintenance. However, the following point must always be observed:

- After completing the drilling work, clean the core drill rig from dirt and dust and, if necessary, grease the rig for easier operation.
- After finishing work with the stand, grease the shafts and their threads. Make sure that no water runs out of the carriage and there is no dust buildup on the carriage.
- If possible, do not use water to clean the drill stand, as some metal parts can accumulate flash rust and this can lead to malfunction. Make sure that the drill stand is dry after use and cleaning.
- In the front area of the drill slide there are 4 rollers. In the rear area there are 4 eccentric clamps. In the course of time, wear may occur on the rollers. If this is the case, tighten the 4 eccentric clamps slightly until the slide can be moved again without play. If it is no longer possible to readjust the eccentric clamps, all 4 track rollers must be replaced to prevent further damage to the gear shafts and the gear rack.

- Always pay attention to the wear listed above. Replace the rollers and/or the eccentric clamps if necessary. If the problem persists, replace the drill column.
- Check the stability of the drill stand before each use. If the base plate of the drill stand is damaged, replace it before using the drill stand.
- Periodically perform a visual and functional check to ensure that all terminals and moving parts are fully functional.
- Only use the drill stand up to the maximum permissible diameter. This can be found on the type plate of the respective stand.
- Failure to comply with this specification may result in malfunction during operation of the drill stand as well as injury to the operator.

Maintenance and inspection plan

Regular inspection according to the maintenance and inspection schedule is urgently required. Shorten the intervals between maintenance if you use the product very frequently.

Maintenance parts	each time before use	monthly or after 25 hours of work	every 3rd month or after 50 working hours	annually or after 200 working hours
Greasing the needle bearing of the gear shaft	√	√	√	√
Lever-locking device	√	√	√	√
Clamping and wheels	-	√	√	√
Drill column	-	-	-	√
Gear shaft and gears	-	-	-	√
all clamping parts and threads	√	√	√	√
Angle clamp	√	√	√	√
Rack	√	√	√	√
Base plate welds	-	√	√	√

Troubleshooting

Error	Cause	Troubleshooting
the sled wobbles	Tensioner worn	Retighten the 4 eccentric clamps.
the gear shaft is jammed	all 4 rollers worn out	Replace all 4 casters.
Concentricity of the drive shaft on the rack	Wear on the gear shaft or the gear rack	Replace the worn part.
Carriage lever lock cannot engage on the toothed rack	The lever lock has deformed or the weld seam is coming loose.	Replace the lever lock.
After replacing all the eccentric clamps and aligning the impellers, the carriage movement is still unreliable.	The drill column is worn.	Replace the drill column.
The angle adjustment on the drill stand cannot be tightened at 45°.	When tightening the locking screw for the angle adjustment, the nut was overtightened.	Replace clamp for angle adjustment on the back of the drill column
Drill motor cannot be clamped	Wear on the clamping surface	Replace the clamping bracket ø60mm.
Drill column starts to wobble slightly	Crack on the weld of the base plate to the column holder	Replace the base plate of the drill stand.

Exploded view

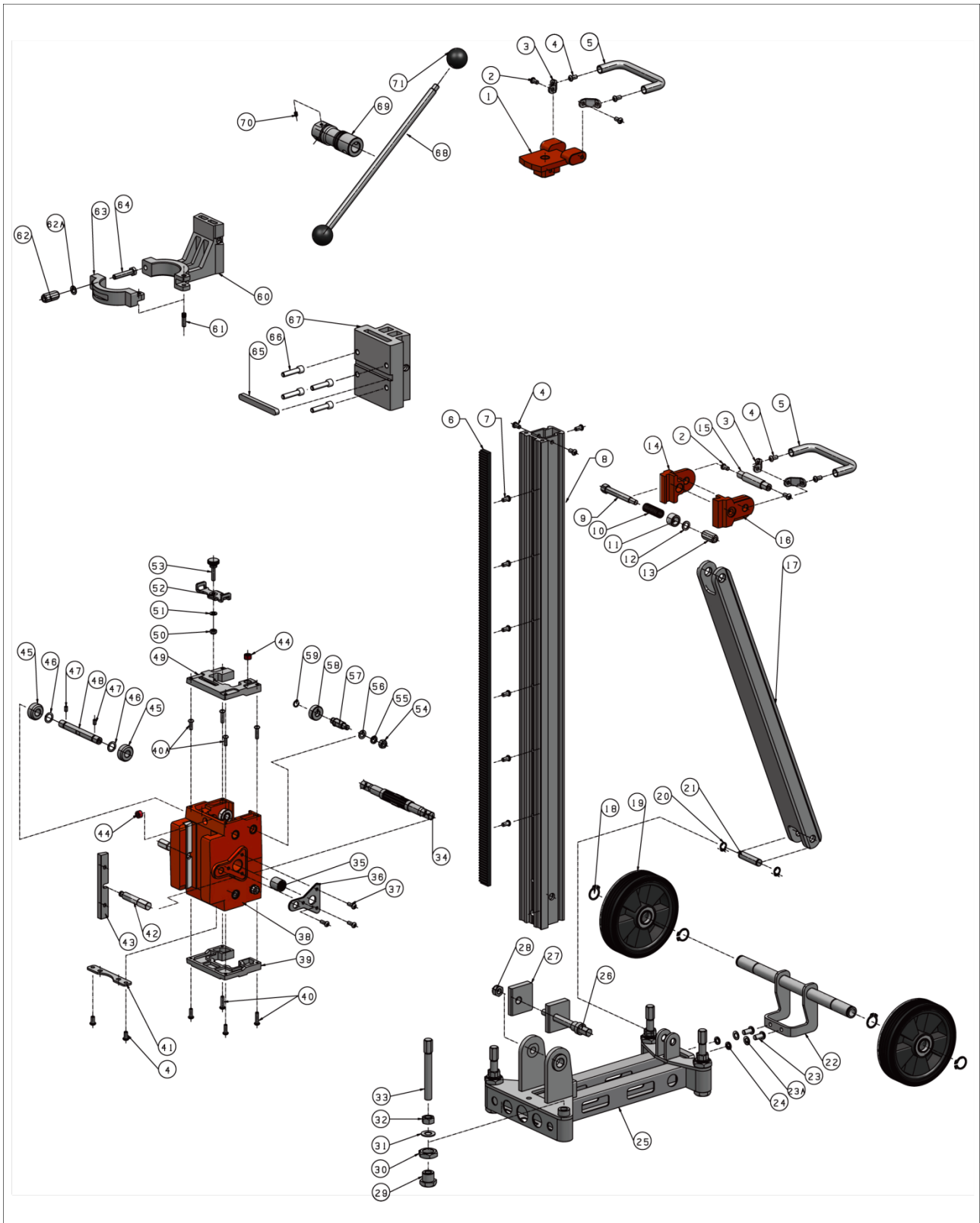

Nr .	Designation	Q u a n t i t y	Nr .	Designation	Q u a n t i t y
1	Column protection top	1	37	Hexagon socket mushroom head screw M5x15	6
2	Hexagon socket screw M6x17 Φ 8x6	4	38	Sledge	1
3	Connector of the rear handle	4	39	Bottom sled guard	1
4	Hexagon socket mushroom head screw M6x12	9	40	Hexagon socket mushroom head screw M5x20	8
5	Rear handle	2	41	Weighing plate	1
6	Rack M1,5x800=L	1	42	Cradle locking bolt	2
7	Hexagon socket mushroom head screw M6x10	6	43	Iron wedge	2
8	Column L=900mm	1	44	Spirit level	2
9	Hexagon bolt M10x75	1	45	Positioning wheel	4
10	Spring Φ 13x Φ 1.4x50=L	1	46	Washer Φ 17,8x Φ 12,3x0,5	4
11	Spacer	1	47	Grub screw with cone point M5x10	4
12	Washer Φ 16x Φ 10.6x1.5	1	48	Front wheel shaft	2
13	Hexagon nut M10x30 S=13	1	49	Top sled guard	1
14	Right Angle Locking Clamp	1	50	Hexagonal lock nut M6	1
15	Positioning mandrel	1	51	Washer Φ 12x Φ 6.2x1.5	1
16	Left angle clamping	1	52	Slide lever lock	1
17	Back support 35x50x625	1	53	Shoulder screw M6x25	1
18	Circlip Φ 20 (optional)	4	54	Clamping nut M8	4
19	6" wheel with bearing (optional)	2	55	Spring washer Φ 15x Φ 8.6x10	4
20	Circlip Φ 12	2	56	Washer Φ 15x Φ 8,6x10	4
21	Positioning shaft of the back support	1	57	Eccentric shaft	4
22	Wheelset holder (optional)	1	58	Eccentric clamp	4

2 3	Hexagon socket mushroom head screw M8x16 (optional)	2	5 9	Constant part ring Φ 6	4
2 4	Washer Φ 8 (optional)	2	6 0	Φ 60mm clamp mount	1
2 5	Base plate	1	6 1	Knurled cylindrical pin Φ 6	1
2 6	Column mounting	1	6 2	Hexagon nut M8x30 S=13	1
2 7	Column block	2	6 3	Clamping plate	1
2 8	Hexagonal lock nut M10	1	6 4	Clamping bracket screw M8x60	1
2 9	Socket insert	4	6 5	Key 10x8x100	1
3 0	Hexagon nut M20xP1.5 T=9 S=30	4	6 6	Spacer	4
3 1	Washer Φ 24x Φ 10,6x1,5	4	6 7	Spacer for motor mounting T=50mm	1
3 2	Hexagon nut M12	4	6 8	Crank	1
3 3	Leveling screw M12x85	4	6 9	Feed crank body S=13	1
3 4	Crankshaft M1,5x11T	1	7 0	Ball plunger M5x8	3
3 5	Needle bearing HK152020	2	7 1	Knob M10x35	2
3 6	Cover plate	2			

Environmental protection

Raw material recovery instead of waste disposal!

To avoid transport damage, the device must be delivered in sturdy packaging. Packaging as well as device and accessories are made of recyclable materials.

The plastic parts of the device are marked according to the material. This enables environmentally compatible, sorted disposal via the collection facilities offered.

Warranty

In accordance with our general terms and conditions of delivery, a warranty period for material defects of 12 months applies in business transactions with companies (proof by invoice or delivery bill). Damage due to natural wear and tear, overloading or improper handling remains excluded from this. Wear parts such as the column, the tensioner and the locating wheels or needles etc. are excluded from the warranty. Damage caused by material or manufacturer defects will be remedied free of charge by repair or replacement. Complaints can only be accepted if the device is sent to the supplier unassembled.

EC Declaration of Conformity

It is necessary that the machine operated with this drill stand (e.g. DKB-PRO series) complies with the requirements described in the technical data of the drill stand (e.g.: drill diameter, machine mounting). We hereby declare that this unit has been designed in accordance with Directive 2006/42/EC. Commissioning of this drilling unit is prohibited until it has been determined that the power tool to be connected to this unit complies with the provisions of Directive 2006/42/EC (recognizable by the CE marking on the power tool)

Name and address of the person authorized to compile the technical documentation:

Kernlochbohrer GmbH
Geigersbühlweg 52
72663 Großbettlingen

Location: Großbettlingen
Date: 17.05.2023

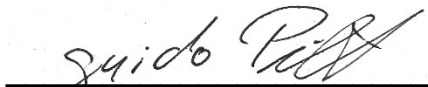

Guido Pillat
Chief Executive Officer